

REFLEX[®]

Trouble-shooting Manual FIELD FIRING ASSEMBLY PART NUMBER 12M03-00117-03

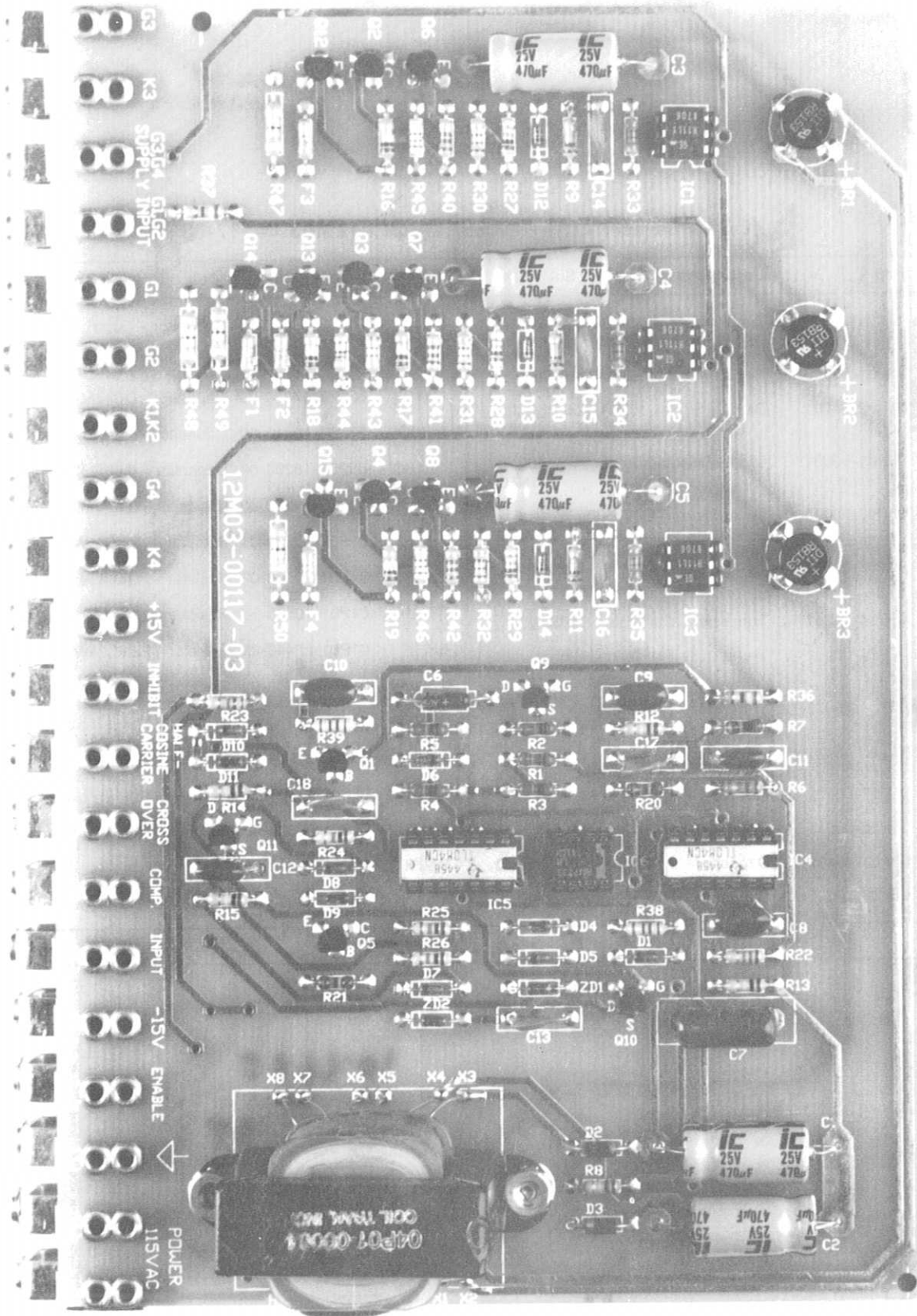

REFLEX® FIELD FIRING ASSEMBLY

PART NUMBER 12M03-00117-03
SCHEMATIC DIAGRAM 12M03-00117-03

I. SPECIFICATIONS

SUPPLY:

- 120V AC $\pm 10\%$
- 50/60 Hz, single phase

TEMPERATURE:

- 0° to 40°C (32° to 104°F)
- 50°C in cabinet

INPUTS:

A. Firing Control Input:

Operational Amplifier with summing junction and output connected to external terminals for components as required to establish gain and feedback compensation. The amplifier is connected in an inverting configuration and causes firing of a thyristor power circuit when the input has a net negative value.

B. Other Inputs:

- 1) "Enable" input allows circuit to be reset to zero for field economy and during power up.
- 2) "Inhibit" input allows circuit to be totally disabled when the system requires this function.
3. "Crossover" input connects to an external crossover circuit for DC motor operation above base speed.

OUTPUTS:

A. Firing Signal:

Four Firing Signal Outputs; two isolated and two with a common output for connection to the two legs of a single phase converter with a common cathode.

Magnitude: Train of pulses; 14V nominal open-circuited, 300mA short-circuited.

Range of Control: From continuous signal at maximum output to Phase Control from 0° to a maximum delay of approximately 160° at End Stop.

B. Half Cosine Wave for use as a timing waveform for REFLEX® 12M03-00113 bi-directional firing.

II. THEORY OF OPERATION

The REFLEX® Field Firing Assembly is a versatile unit that provides isolated gate drive for a variety of single phase power converter configurations to supply DC excitation to highly inductive fields such as those in DC Motors and Generators, AC Alternators, and Eddy Current Clutches and Brakes. The field is discharged regeneratively when reducing current to improve response.

When used with the REFLEX® Bi-directional Output Adaptor it provides bi-directional field current for applications such as reversing field control of a DC Generator, a Field Reversing Regenerative DC Motor Drive, or for alternate excitation of two fields such as an Eddy Current Clutch and Brake.

When used with the REFLEX® Crossover Assembly, the speed range of a DC Motor is extended by field weakening in either regenerative or non-regenerative drives.

The REFLEX® Field Firing Assembly consists of the following elements as shown in the Simplified Schematic Diagram (Figure 1):

- | | |
|--------------------------|---------------|
| 1. Power Supply | 4. Comparator |
| 2. Half-Cosine Generator | 5. Gate Drive |
| 3. Summing Amplifier | |

1. Power Supply — The power supply uses a transformer with four identical 12 volt secondary windings.

One 12 volt winding in conjunction with diodes D2 and D3 and two 470MF filter capacitors provide a nominal plus and minus 15 volts DC for the Half-Cosine Generator, Summing Amplifier and Comparator.

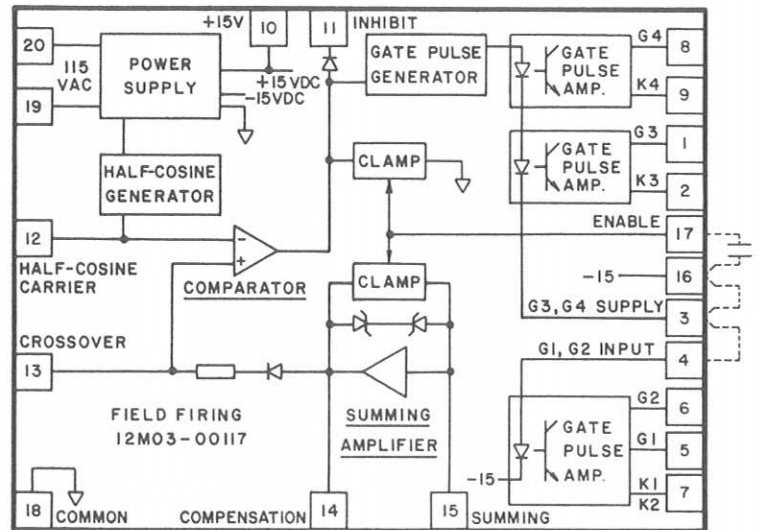

FIGURE 1. SIMPLIFIED SCHEMATIC

Each of the other three 12 volt windings with a bridge rectifier and 470MF filter capacitor provides an electrically isolated power supply for the Gate Drive.

- Half-Cosine Generator** — If the relationship between firing angle and DC output of a single phase controlled rectifier bridge is analyzed, it is found that:

$$V_{dc} = .45 E_{ac} (1 + \cos a) \quad \text{EQ. 1}$$

Where " V_{dc} " is the average DC value for a given half cycle of the AC wave, " E_{ac} " is the RMS value of the AC waveform, and " a " is the firing angle. Therefore, when a cosine relationship between input firing signal and firing angle is established, the DC output will be a linear function of the input signal. Linearity allows accurate open loop control of output voltage, simplifies closed loop analysis and improves performance.

The integrator 4I(A) receives a nominal 12 volts AC from the power supply transformer and using a 220K ohm resistor and .047MF capacitor for scaling, produces a nominal 2.5 volt cosine wave for 60 Hz and 3.0 volts for 50 Hz.

Because of the full-wave nature of a power bridge, a half-cosine wave is needed for each of the half cycles of the AC line. This requirement is accomplished by 5I(A), an op-amp with a gain of one that can be switched between non-inverting and inverting by field effect switching transistor, Q9. The switching is performed at the zero crossing of the AC line.

To maintain purity of the half-cosines, the switching from inverting to non-inverting must not be affected by line noise spikes. For this reason, op-amp 4I(D) performs a second integration on the cosine wave to produce a -sine wave, almost perfectly pure because of the double integration. 4I(C) acts as a comparator to determine the zero crossings and to operate the FET switch accordingly.

To add the "1" to the cosine wave to obtain the (1+cos) function, a peak detector, 5I(B) determines the positive peak of the half-cosine waves, and adds it to the waves. The DC "1" is stored in capacitor C6, which is allowed to discharge slowly to allow the circuit to follow line voltage or frequency variations. The final resulting waveform is connected to one input of the Comparator 5I(C).

To establish the firing angle, " a " in Equation 1, a variable positive DC voltage is connected to the other input of the Comparator, and a firing signal is produced at the time when the "1+cos" voltage becomes more negative than the DC voltage.

The "1+cos" signal is shifted slightly negative with respect to zero to provide an "End Stop," pulse for regenerative discharge of the field current. The "1+cos" signal is also brought out to terminal 12 as a "Half-Cosine Carrier" for use with the REFLEX® Bi-directional Adaptor.

- Summing Amplifier** — Input amplifier 6I provides the means for summing reference and feedback signals. Its input, pin 2, is brought out to terminal 15 and its output, pin 6, is brought out to terminal 14 to allow flexibility in input scaling, and selection of various feedback networks to suit a particular application.

With the input and output resistors connected for unity gain, a negative signal from 0 to 6 volts will provide a control range from 0 to full output. More commonly, a positive field current feedback signal of 2 volts at maximum field current is applied to the input, terminal 15, through a 2.2K resistor to provide a nominal 1mA feedback current to the summing junction at pin 2 of 6I. A negative reference current slightly in excess of the feedback current applied to the same summing junction will produce full current to the field. Zener diodes ZD1 and ZD2 act as a clamp to limit output voltage of the Summing Amplifier to plus or minus 6 volts.

To operate the assembly, a negative 15 volts from any source with respect to circuit common must be applied to "Enable" terminal 17. If the "Enable" terminal is open circuited, field effect switching transistor, Q10, conducts, clamping the output of the Summing Amplifier to zero.

- Comparator** — The output of the Summing Amplifier is compared to the (1+cos) wave by op-amp 5I(C), acting as a voltage comparator. Its output drives a pair of transistors, Q5 and Q1, to produce gate signals to the thyristors in the power converter.

If the output of the Summing Amplifier is negative, no gate signals appear. As it moves positive, gate signals occur earlier and earlier in the half-cycle until full conduction occurs when the output of the Summing Amplifier is more positive than the positive peaks of the (1+cos) wave.

One input, pin 10, of the Comparator is brought out to terminal 13 for use with the REFLEX® Crossover Assembly.

The input of transistor Q5 is short circuited by FET switch Q11 at the same time the Summing Amplifier is clamped to avoid indiscriminate firing on power up. It can also be disabled by connecting the "Inhibit," terminal 11, through a 10K resistor to minus 15 volts.

- Gate Drive** — Transistors Q5 and Q1 provide signals to the diode section of two or three Logic opto-couplers 1I, 2I, and 3I in series. A jumper option is provided to allow driving opto-coupler 2I from a separate source.

Fast response is achieved by reversing the field voltage for regenerative discharge of the field as long as the field is conducting to provide fast field discharge. The half-cosine wave is biased to generate an "End Stop" pulse in the absence of an input signal near the end of the AC supply cycle.

If the field is conducting near the end of a negative half cycle, the "End Stop" pulse prevents conduction in the next positive half cycle by commutating the field current to a thyristor pair that conducts in the next negative half cycle.

The isolated output of each of the three opto-couplers drives an oscillator that drives a Darlington power transistor which provides the gate drive to the thyristors. Transistors Q13 and Q14 provide two outputs for individual gate drive to each of two thyristors with a common cathode connection.

The SCR drive consists of a train of high energy pulses that appear for a time determined by the comparator output.

COMPONENT LIST — ASSEMBLY #12M03-00117-03

Symbol	Part #	Description (Acceptable Substitute) *	Symbol	Part #	Description (Acceptable Substitute) *
1T	04P01-00004	Transformer - 120V AC PRI, two 10V SEC @ 50mA (Coil Trans.-120-4-10)	7C	03P03-10503-00	Capacitor - 1.0MF, 35V, Tantalum
1-3BR	05P01-00003	Rectifier Bridge - 50V, 1A (EDI-PF50)	8-11C	03P03-22501-00	Capacitor - 2.2MF, 15V, Tantalum
1,4-14D	05P02-00001	Diode - Signal, 50 mA, 200 PIV (1N4148)	11,12C	03P07-47310-00	Capacitor - 0.047MF, 100V, Film
2,3D	05P01-00001	Diode - Medium Power, 1 A, 400 PIV (1N4004)	8-10C	03P07-10410-00	Capacitor - 0.1MF, 100V, Film
1,2ZD	05P03-00005	Zener Diode - 6.8V, 500mW, 10% (1N5235B)	17,18C	03P06-10205-00	Capacitor - 0.001MF, 50V, Ceramic
9-11Q	02P05-00001	Transistor - N Channel JFET (2N4093)	13-16C	03P06-10305-00	Capacitor - 0.01MF, 50V, Ceramic
12-15Q	05P04-00011	Transistor - Darlington (MPSA63)	1-5R	01P02-10031-01	Resistor - 100K, ½W, 1%
1-4Q	05P04-00001	Transistor - PNP, Small Signal (2N3638A)	6R	01P01-22500-02	Resistor - 2.2M, ¼W, 5%
5-8Q	05P04-00002	Transistor - NPN, Small Signal (2N3392)	7R	01P01-10500-02	Resistor - 1.0M, ¼W, 5%
1,2,3IC	05P10-00004	Opto-Isolator (H11L1)	8R	01P01-22400-02	Resistor - 220K, ¼W, 5%
4-5IC	05P08-00002	Quad Op-Amp (TI-TL084)	12-19R	01P01-10400-02	Resistor - 100K, ¼W, 5%
6IC	05P08-00011	Op-Amp (LM741)	20-21R	01P01-68300-02	Resistor - 68K, ¼W, 5%
1-5C	03P01-47102-01	Capacitor - 470MF, 25V, Electrolytic	22R	01P01-27300-02	Resistor - 2.7K, ¼W, 5%
6C	03P07-10510-00	Capacitor - 1.0MF, 100V, Film	23R	01P01-15300-02	Resistor - 15K, ¼W, 5%
			24-29R	01P01-10300-02	Resistor - 10K, ¼W, 5%
			38,39R	01P01-22200-02	Resistor - 2.2K, ¼W, 5%
			47-50R	01P01-47000-02	Resistor - 47, ½W, 10%

* OR EQUAL

REFLEX INC.

303 ALLENS AVENUE, BOX 1515, PROVIDENCE, RI 02901
401/941-4444 TLX 880060

BULLETIN TM201-0787
Copyright© 1987 Printed in U.S.A.

BENCH TEST

TEST MATERIAL REQUIRED:

- 1 - 120V AC line cord
- 1 - 5K, 2 watt potentiometer
- 1 - 100K, ¼ watt resistor
- 2 - 10K, ¼ watt resistors
- 4 - 47 ohm, ½ watt resistors
- 11 - Clip leads
- 1 - Oscilloscope (Tektronix 2213 or equal)
- 1 - Digital Voltmeter (Beckman HD-110 or equal)

1. Attach a 5K Potentiometer with the high end (CW) to terminal 16, low end (CCW) to terminal 18, and wiper to one end of a 10K Resistor. Attach the other end of this resistor to terminal 15. Turn the 5K Potentiometer full CCW.
2. Attach a 10K Resistor from terminal 15 to 14.
3. Connect jumpers from terminal 16 to 17 and from 3 to 4.
4. Attach a 47 Ohm ½ Watt Resistor between each of the following pair of terminals: 5 & 7, 6 & 7, 1 & 2, and 8 & 9.
5. Apply 115V AC to terminals 19 & 20.
6. With an oscilloscope, check the waveform at terminals 12 (+) and 18 (-). Set the oscilloscope vertical input to 1V per division, and sweep rate to 2mS/division. Read a ½ cosine pattern of 5V peak, which repeats at 8.3mS intervals. The negative peak of the half cosine wave should be at approximately DC zero.
7. Change the oscilloscope vertical input to 2V per division.
8. Place the oscilloscope across each of the 47 Ohm resistors and read a train of pulses of approximately 0.4 mS width, which repeats at 8.3 mS intervals.
9. Turn the 5K potentiometer fully CW and back to zero. The pulse train should change width until it becomes continuous and then return to original pulse when potentiometer is returned to 0.
10. Repeat steps 8 and 9 with the other 3 resistors. To keep polarity on the oscilloscope the same, use terminals 7, 2 and 9 as common.

11. Select any one of the resistors and set the 5K potentiometer CW until just reaching the continuous condition. Connect a 100K resistor from terminal 16 to terminal 13. The continuous train should become a 0.4 mS pulse train.
12. Connect a 10K Resistor between terminals 16 and 11. All pulses should disappear. Disconnect this resistor.
13. Remove the jumper from terminal 17 and the pulses should disappear.

VOLTAGE CHECK

1. The primary voltage of transformer 1T, leads H1 and H2 (terminals 20 and 19), should be 115V AC.
2. The secondary voltage of 1T should be 120V AC nominal in each of four windings:
 - leads X3 & X4 (terminal 18 to the anode of D2)
 - leads X7 & X8 (AC input to BR2)
 - leads X5 & X6 (AC input to BR3)
 - leads X1 & X2 (AC input to BR1)
3. Measure +12V DC nominal between terminal 18 (common) and terminal 10.
4. Measure -12V DC nominal between terminal 18 (common) and terminal 16.
5. Measure +15V DC nominal between terminal 7 (common) and the positive end of capacitor C4.
6. Measure +15V DC nominal between terminal 2 (common) and the positive end of capacitor C3.
7. Measure +15V DC nominal between terminal 9 (common) and the positive end of capacitor C5.
8. Use an oscilloscope to verify that waveforms are as shown on the schematic diagram.

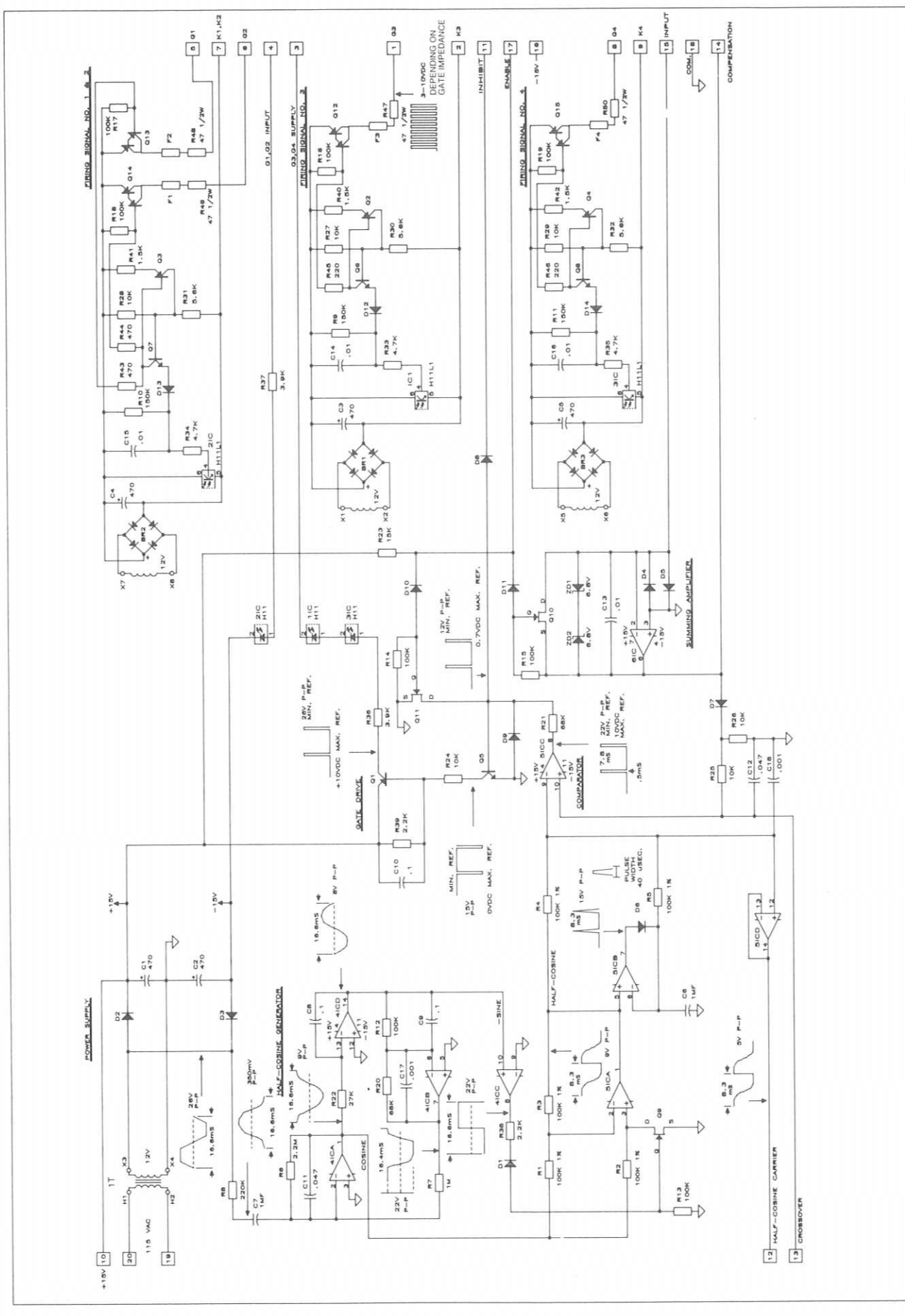

REFLEX INC.
 CEDARBURG, WI

TITLE: SINGLE PHASE FIRING CIRCUIT
 CONVERTIBLE TO BI-DIRECTIONAL

S14 Document Number
 13403-00117-03

REV
 C
 13403-00117-03

13403-00117-03 1 of 1

THIS DOCUMENT AND ALL INFORMATION HEREON CONTAINED HEREIN IS UNCLASSIFIED EXCEPT WHERE SHOWN OTHERWISE. IT IS RELEASED IN FULL TO THE PUBLIC. IT IS NOT TO BE REPRODUCED OR TRANSMITTED IN ANY FORM OR BY ANY MEANS, ELECTRONIC OR MECHANICAL, INCLUDING PHOTOCOPYING, RECORDING, OR BY ANY INFORMATION STORAGE AND RETRIEVAL SYSTEM, WITHOUT PERMISSION IN WRITING FROM THE NATIONAL ARCHIVES. FOR ANY OTHER PURPOSE THAN THAT FOR WHICH IT IS DISCLOSED.