

REFLEX®

Trouble-shooting Manual MODEL 219 PULSE AMPLIFIER PART NUMBER 12M03-00120-02

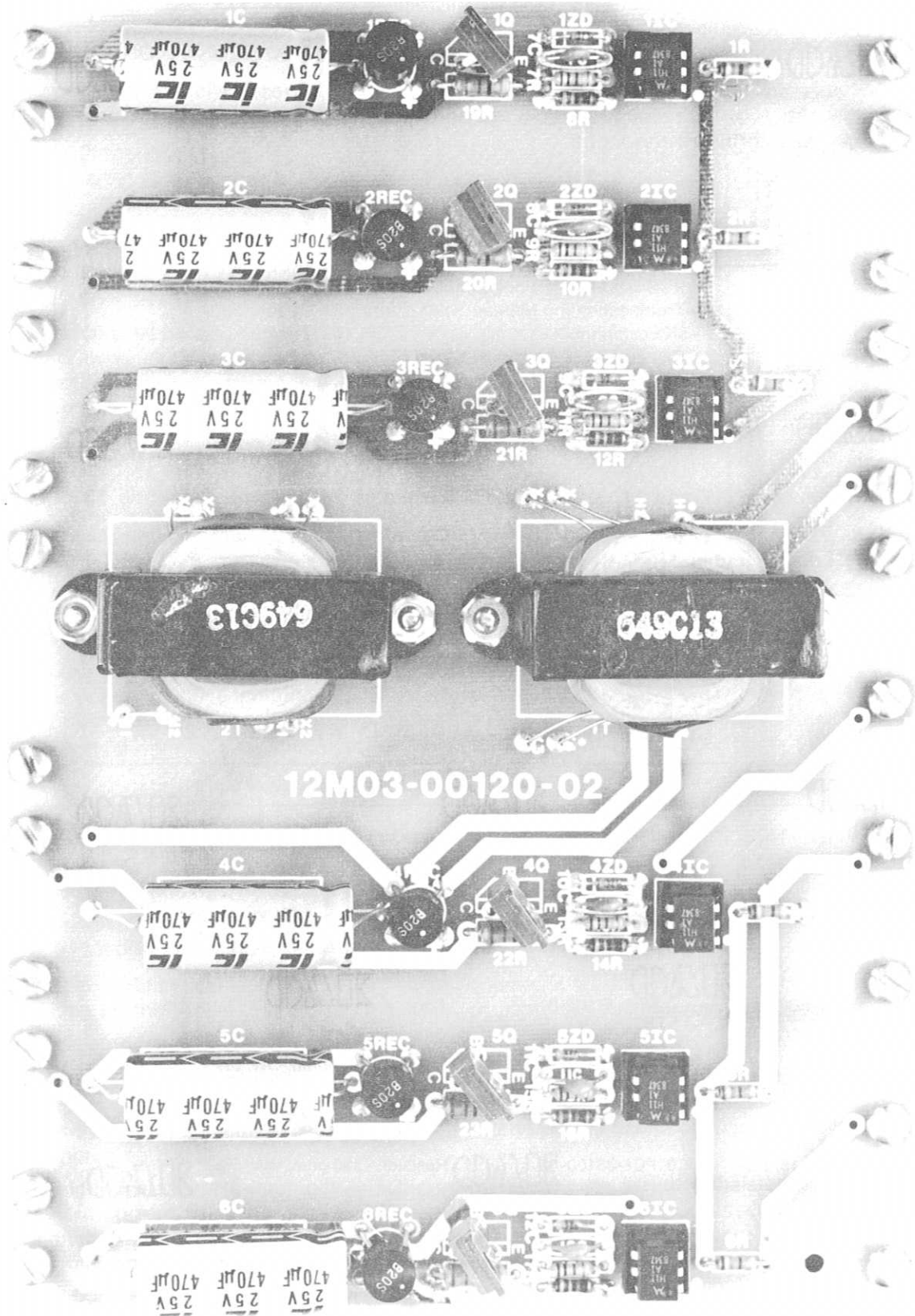

REFLEX® MODEL 219 THREE-PHASE PULSE AMPLIFIER

PART NUMBER 12M03-00120-02
SCHEMATIC DIAGRAM 12M03-00120-02

I. SPECIFICATIONS

SUPPLY

- 120 Volts AC \pm 10%
- 50/60 Hz, Single phase

AMBIENT TEMPERATURE

- 0° to 40°C (32° to 104°F) (50°C in cabinet)

INPUT

- 50 mA into a parallel load of 150 ohms and light-emitting diode of opto-coupler (approximately 1.25V)

OUTPUT

- 0.5 Ampere pulses into a short circuit load, approximately 12 volts open circuited. Pulse duty cycle not to exceed 5% with a short circuit load. Rise time is typically less than 500 nano-seconds.

FIGURE 1
SIMPLIFIED SCHEMATIC

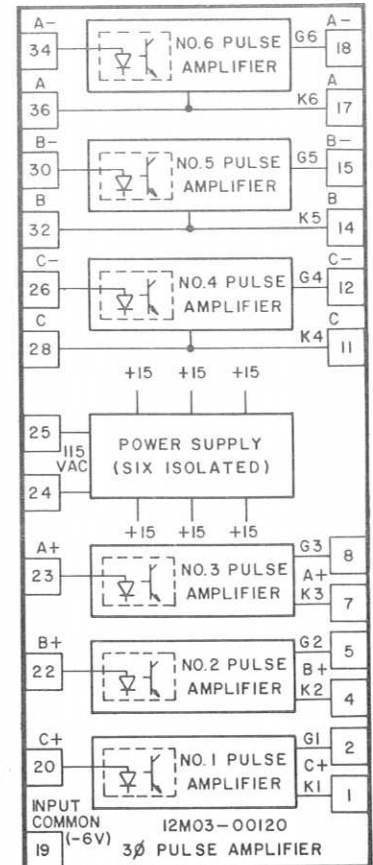

II. THEORY OF OPERATION

The Model 219 Pulse Amplifier is used with the Model 218 Pulse Generator to provide six isolated outputs with high noise immunity to the gates of a three-phase, full-wave DC thyristor power converter. It may also be used with a three phase, half-wave DC or three phase AC power converter. It consists of the following elements as shown in the simplified schematic diagram (Figure 1).

1. Power Supply
2. Isolator
3. Gate Drive

1. **Power Supply** – The power supply consists of two transformers each with three identical 10 volt secondary windings for a total of six windings.

A bridge rectifier with a 470 MF filter capacitor on each winding supplies a nominal 15 volts DC to an opto-coupler and gate drive transistor.

2. **Isolator** – Electrical isolation for each of six outputs is furnished by an opto-coupler whose input is driven by the Model 218 Pulse Generator, or other suitable source.

Each opto-coupler output drives an amplifier which provides the gate drive to a thyristor.

3. **Gate Drive** – Each of six outputs is supplied by a Darlington power transistor. Use of six separate outputs avoids potentially high circulating currents in the pulse leads to the cathodes of the three thyristors with a common cathode connection, and allows use in configurations that do not have a common cathode.

A high level of noise immunity is achieved by biasing the output transistors so that a significant output current from the opto-coupler is required before an output pulse is generated. Unwanted signals, which may be caused by high dv/dt acting on the input-output capacitance of the opto-coupler are effectively bypassed without triggering an output.

Although the opto-coupler itself has an unacceptably slow rise time, only a small portion of the rising waveform is needed for full output, and the output pulse has a rise time of less than 0.5 microseconds. Output pulses, therefore, qualify as "hard firing."

III. BENCH TEST

1. With an Ohmmeter measure "0" Ohms from terminals 28 to 11, 32 to 14, and 36 to 17.
2. Connect 47 Ohm ½ Watt resistors to each of the following output terminals: 1-2, 4-5, 7-8, 11-12, 14-15, and 17-18.
3. Apply 115V AC between terminals 24 and 25.
4. Apply an input pulse of approximately 50-100 microseconds width, 12V peak and a 3-10 millisecond repetition rate, to the following input terminals one at a time: 20, 22, 23, 26, 30, 34, with terminal 19 common. The input pulse may be obtained from a Reflex 12M03-00112 Pulse Generator Assembly.
5. With a suitable osilloscope read one, and only one, output corresponding to each input, a pulse of approximately 12V peak, with sharply defined rise and fall times (slight overshoot acceptable). The width and repetition rate should match the input.

PCB TERMINALS	
INPUT	OUTPUT
19-20	1-2
19-22	4-5
19-23	7-8
19-26	11-12
19-30	14-15
19-34	17-18

TEST MATERIAL REQUIRED:

- 1 - Ohmmeter
- 1 - Oscilloscope (Tektronix 2213 or equal)
- 1 - Pulse Generator (Reflex 12M03-00112)
- 1 - PCB Mounting Rack (12M04-00020)
- 1 - Troubleshooting Manual TM218 (for Pulse Generator)
- 1 - 5K Pot (connect to terminals 16 - CCW, 15 - wiper, 9 - CW on 12M03-00112 Pulse Generator)
- 3 - Clip leads
- 1 - 120V AC Line Cord with spade lugs one end

IV. VOLTAGE CHECKS

1. The primary voltage of 1T and 2T, leads 1 and 2 (terminals 24 and 25), should be 120V AC.
2. The secondary voltage of 1T and 2T should be 10V AC nominal (each winding). Voltage can be read at the AC input to the bridge rectifier 1REC through 6REC.
3. Voltage across 1C through 6C should be 15 volts DC nominal.
4. Voltage across 1ZD through 6ZD should be 4.3 volts nominal ($\pm 5\%$) when output pulse is present.
5. Use an oscilloscope to verify that the waveforms are as shown on the schematic diagram.

COMPONENT LIST - ASSEMBLY #12M03-00120-02

Symbol	Part #	Description (Acceptable Substitute*)
1T, 2T	04P01-00004	Transformer - 120V AC PRI, four 10V SEC @ 50 mA (Coil Trans. - 120-4-10)
1-6REC	05P01-00003	Rectifier Bridge - 50V, 1A (EDI-PF50)
1-6ZD	05P03-00002	Zener Diode - 4.3V, 500 mW, 5%
1-6Q	05P04-00011	Transistor - PNP Darlington (MPS A 63)
1-6IC	05P10-00001	Opto-Isolator - (GE-H11A1)
1-6C	03P01-47102-01	Capacitor - 470MF, 25V, Electrolytic
7-12C	03P06-10305-00	Capacitor - .01MF, 50V Ceramic
1-6R	01P01-15100-02	Resistor - 150 ohm, ¼W, 5%
7, 9, 11, 13 15, 17R	01P01-10200-02	Resistor - 1K, ¼W, 5%
8, 10, 12, 14, 16, 18R	01P01-33100-02	Resistor - 330 ohm, ¼W, 5%
19-24R	01P01-22001-02	Resistor - 22 ohm, ½W, 5%
		* OR EQUAL

REFLEX INC.

303 ALLENS AVENUE, BOX 1515, PROVIDENCE, RI 02901
401 / 941-4444 TLX 880060

BULLETIN TM219-0287
Copyright © 1987 Printed in U.S.A.

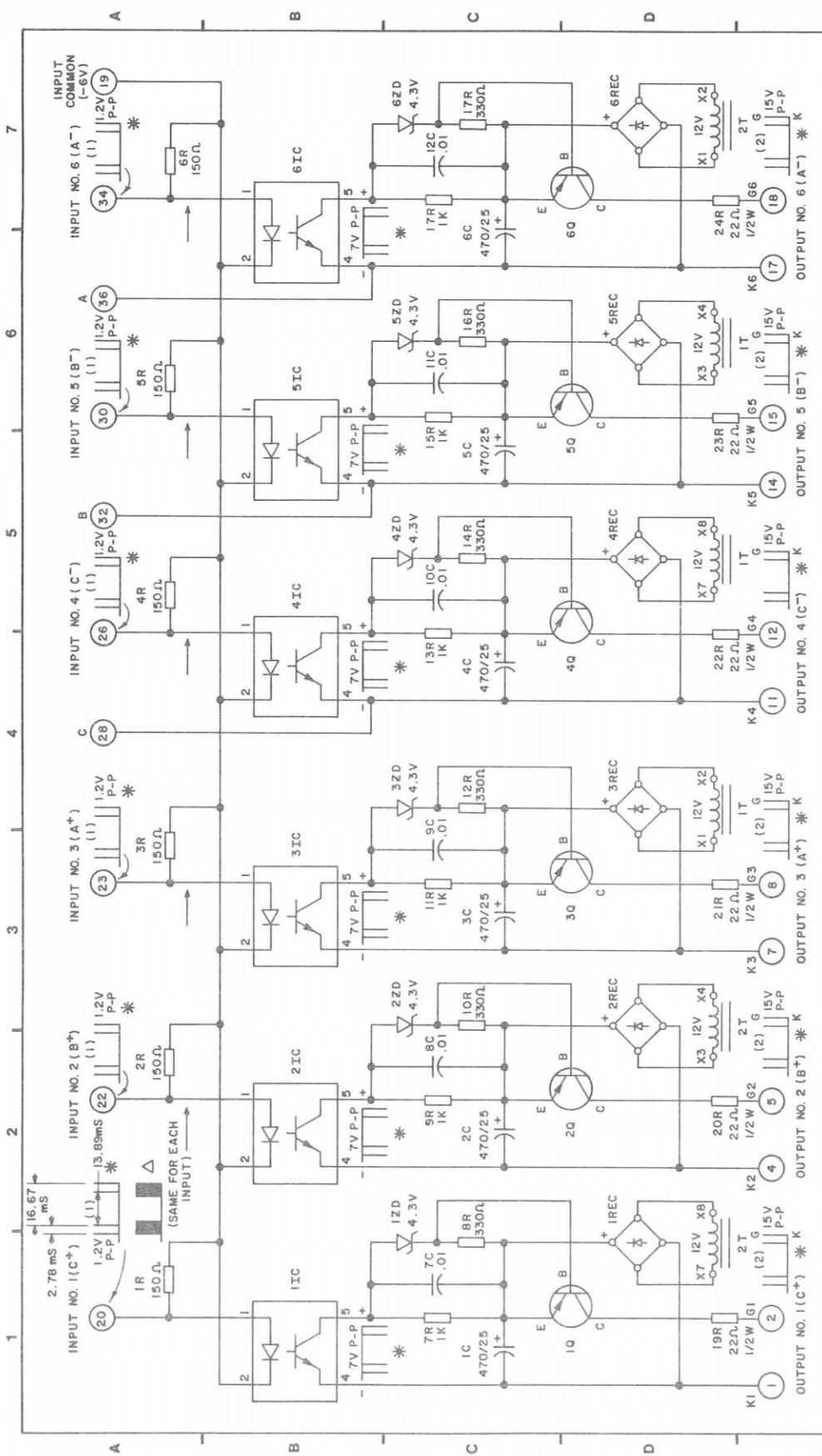

NOTES:
 (1)-COMMON OF SCOPE ON TERMINAL 19
 (2)-THE OUTPUT LOAD IS A 47Ω RESISTOR. SIGNAL WILL BE DIFFERENT IF CONNECTED TO AN SCR. AMPLITUDE WILL VARY WITH GATE LEAD RESISTANCE.
 SIGNALS ON EACH OUTPUT SHOULD BE VIRTUALLY IDENTICAL, IF SIGNALS ON EACH INPUT ARE VIRTUALLY IDENTICAL.

* - WITH ZERO VOLTS REFERENCE ON 12M03-00112
 Δ - WITH SOME REFERENCE VOLTAGE ON 12M03-00112, TERMINAL 15 TO LEFT WITH INCREASE IN REFERENCE.

- SIGNAL FROM PULSE GENERATOR 12M03-00112

PCB NO. 13501-00120-02
 LAYOUT NO. 12M03-00120-02

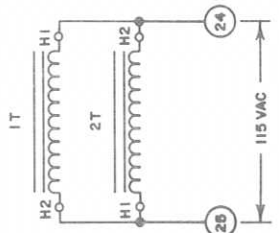

THIS DOCUMENT AND ALL INFORMATION HEREIN CONTAINED, INCLUDING ALL OF THE DETAILS AND CONCEPTS DISCLOSED OR SUGGESTED IS THE EXCLUSIVE PROPRIETARY PROPERTY OF REFLEX INC. NO PART OF THIS DOCUMENT IS TO BE REPRODUCED OR TRANSMITTED IN ANY FORM OR BY ANY MEANS, ELECTRONIC OR MECHANICAL, INCLUDING PHOTOCOPYING, RECORDING, OR BY ANY INFORMATION STORAGE AND RETRIEVAL SYSTEM, WITHOUT PERMISSION IN WRITING FROM REFLEX INC. THIS DOCUMENT IS INTENDED TO BE OBTAINED IN STRICT CONFIDENCE AND IT SHALL NOT BE Duplicated IN WHOLE OR IN PART AND THAT IT WILL NOT BE USED FOR ANY OTHER PURPOSE THAN THAT FOR WHICH IT IS DISCLOSED.

"CONFIDENTIAL"

REV.	DATE	DESCRIPTION	INT.
1	6-10-64	ADD (8) 0.1MFD CAP ACROSS (8) 1K RESISTOR	KH

REV.	DATE	DESCRIPTION	INT.
1	6-10-64	ADD (8) 0.1MFD CAP ACROSS (8) 1K RESISTOR	KH

REV.	DATE	DESCRIPTION	INT.
1	6-10-64	ADD (8) 0.1MFD CAP ACROSS (8) 1K RESISTOR	KH

REV.	DATE	DESCRIPTION	INT.
1	6-10-64	ADD (8) 0.1MFD CAP ACROSS (8) 1K RESISTOR	KH

REV.	DATE	DESCRIPTION	INT.
1	6-10-64	ADD (8) 0.1MFD CAP ACROSS (8) 1K RESISTOR	KH

REV.	DATE	DESCRIPTION	INT.
1	6-10-64	ADD (8) 0.1MFD CAP ACROSS (8) 1K RESISTOR	KH

REFLEX INC. CEDARBURG, WI. PRODUCT: 3 PHASE PULSE AMPLIFIER. PART NO. EX-219. JOB NO.